

Columns	Linear motor	Number of bed base
Maximum standard length	Maximum standard width	Standard heights
Trend / Reverse trend	Cardiac chair	Lateral tilting
CPR	SWL	MPW

## Features

HiTech ACT bed is equipped with the most advanced technology for the patient intensive care. Special design for ICU areas.

Its three rectangular lifting and lateral tilt columns are safety and durability warranty. Multiple options are available to satisfy the patient care necessities, which optimize the work of the caregivers.

Some of their principal features are:

- To transport easier:

Lightweight. It has four castors with high rolling, wear and rust resistance. It has a minimum noise emission whilst moving.

It has a double centralised braking system. By a bar localised on the footboard zone and double pedal placed on the headboard.

- Easy and intuitive using:

Lifting and Lateral tilting systems by three rectangular columns. The columns use also facilitates the bed cleaning, the number of structure pieces is reduced and therefore the infection probability is reduced as well.

Touch screen on the footboard is the principal control to move the bed. Furthermore this screen controls the bed's weighing system.

The bed has a battery, which can perform more than 300 complete movements.

The bed has an anti-fall security system that locks the beds tilting while the rails are lowered.

- Encourage the welfare of patient:

The lateral tilting function allows patient better oxygenation to avoid complications and facilitates daily.

The backrest section is X-ray transparent, ready to use with X-Ray.

Extended bed base until 30 cm.

Double-regression system (16'5 cm). This system minimize the pressure in the sacrum zone of patient to reduce the risk of pressure ulcers.

Articulated footrest section in different positions by gas spring system.

- Other advantages:

4 HPL bed base sections. All of them can be removable without tools except the central section.

Steel structure finished with antimicrobial epoxy-polyester coating, tested according to ISO 22196, resistant to chemical and mechanical agents, finished in RAL 9006.

Polypropylene side rails with hand grip zone to help the patient sitting and exit the bed. Folding system by gas spring.

Easily removable head and footboards with locking system.

Anchored headboard.

4 protection cylinders localised in the corners that avoid the shocks reducing the impacts and damage of bed.

2 guides localise on both sides of bed to hang up drain hooks. There are include four drain hooks on each guide.

4 mattress retainers in feet and thorax.

Customizable vinyls.

- Furthermore the HiTech ACT bed disposes of a wide range of accessories and complements, which provide to comply the hospital and patient needs for their comfort and wellness.



## Technical information

Total length with anchored headboard and footboard	222 cm ± 1 cm
Total width with side rails	101 cm ± 1 cm
Minimum / Maximum height of bed base	50 / 90 cm ± 1 cm
Free height from floor to columns system	5 cm ± 1 cm
Crane passing clearance height	18 cm ± 1 cm
Wheels diameter	15 cm
Width of bed base sections	83 cm ± 1 cm
Length of bed base sections	74'4 / 16'5 / 32 / 61' 5 cm
Length of extended bed base	30 cm ± 1 cm
Bed base double-regression	16'5 cm ± 1 cm
Angle of backrest tilting	65° ± 5°
Angle of legrest tilting	47° ± 2°
Angle of footrest tilting	18° / 7° ± 2°
Angle of Trend / Reverse trend tilting	18° / 18° ± 2°
Angle of lateral tilting	20° ± 2°
Maximum patient weight (MPW)	185 kg.
Safe working load (SWL)	250 kg.
Unladen bed weight	From 125 kg. to 150 kg.
Recommended dimensions of mattress*	85 x 200 cm ± 1 cm

\*The mattress of this bed has cut corners.

## Configuration

### Standard

Protection	Transport	Wellness	Others
Integral side rails	Double wheels Ø150mm	Spring gas for foot section	Drain hooks
Removable curved footboard	Braking system by bar on footboard	HPL bed base	Weighing on touch screen
Anchored headboard	Braking system by double pedal on headboard		Battery
			Pardo P.2716 vinyl (1)

### Optional

Protection	Transport	Wellness	Others
	5th wheel	Table under footboard	Braking alarm
			Light under bed (2)
			Customizable vinyl (3)

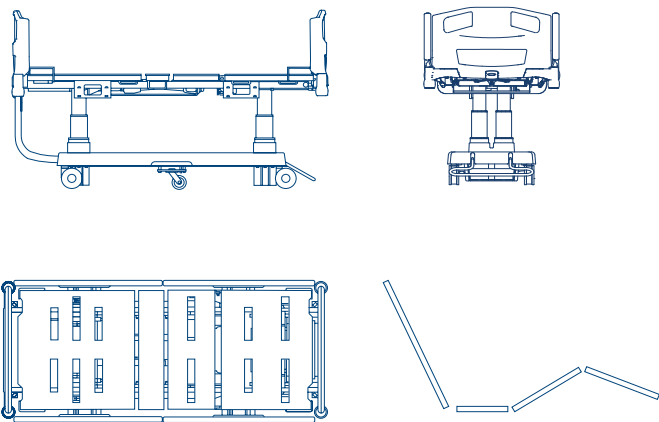

● Mandatory standards  
○ Changeable options

## Control remote configuration

### Mandatory controls in all beds

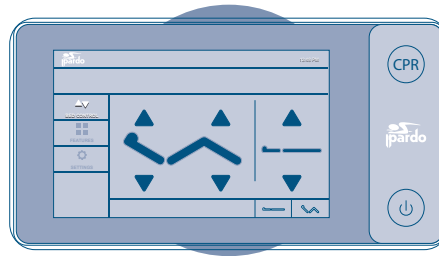

Touch screen

### Other controls to add

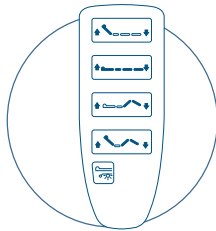

Patient control with light

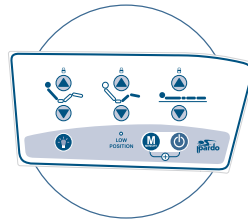

Membrane of side rails

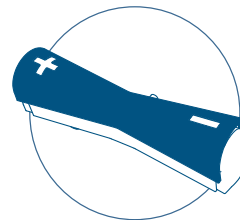

Lifting pedal

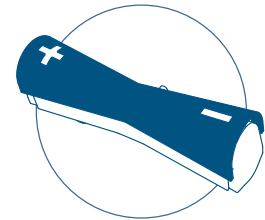

Lateral tilting pedal

## Electrical information

Lifting and Lateral tilting bed system	3 columns
Tilting backrest system	Linear actuator
Tilting legrest system	Linear actuator
Voltage	120 V or 220 V / 50 - 60 Hz
Frequency	50 - 60 Hz
Electrical shock protection / penetration liquid	Class I / Type B / IPX6
Maximum consumption	Máx. 3 15A (Maximum 400 W)
Intermittent operation of actuator	10% 2 min. - 18 min.

## Accessories



IV-Pole with 2 hooks



IV-Pole with 4 hooks



Trapeze bar



Techno Trapeze bar

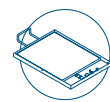

X-ray cassette tray

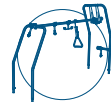

Balkan frame



Tilting table



Tank holder

## Standards

- UNE EN ISO 12100 Standard.
- UNE EN 20324 Standard.
- UNE EN 60204-1 Standard.
- UNE EN 60601-1 Standard.
- UNE EN 60601-1-2 Standard.
- UNE EN 60601-2-52 Standard.
- UNE EN 45501-16 Standard.

## EN 60601-2-52:2010 test

- Electrical and Electromagnetic test made in ITA (Instituto tecnológico de Aragón).
- Mechanical test of side rails made in IBV (Instituto Biomecánico de Valencia)

## INCOMPATIBILITIES:

2 - The light under bed must configure with one of the next control:

- Patient hand control with light.
- Side rail membranes.

## NOTES:

1 - The standard vinyls have these features:

- Blue colour, code P.2716-C.
- Only including the Pardo logotype in white colour.

3 - The customizable vinyls depends on quantity of order (Seeing "Delivery time"):

- Colour: If it is possible, the background will made by one colour.
- Logotype: It is possible including the customer logotype. Always the logotype will be white, unless the client requests otherwise.

## DELIVERY TIMES:

Beds (From the mechanised of order).

### Standard HiTech ACT bed:

- Order < 5 units: Consulting with production department.
- Order < 75 units: 5 - 6 weeks.
- Order > 75 units: 7 - 8 weeks .

### Special HiTech ACT bed:

- Consulting with production department.

Vinyls (From the mechanised of order).

- Order < 25 units: It made by digital printed. It is possible add some colour. Normal delivery times: 10 days.
- Order > 25 units: It made by serigraph. When there are more colours, the prize is expensive. Normal delivery times: 3 weeks.

## CODE PRODUCTS FOR ORDER (ONLY FOR PRODUCTION DEPARTMENT):

- BED Code ( E.G SC8016000000XXX)
- SIDE RAILS Code ( E.G: BC8012500000XX)
- HEADBOARD - FOOTBOARD Code ( E.G.: RC80125000000XXX)
- VINYL Code ( E.G: AC80130000000XX)
- USER MANUAL Code ( E.G: XX8499900000XXX)  
Sent the pdf by email.
- DOCUMENTATION code (E.G: XX8499800000XXX)  
Mechanize one "Fast Data sheet" per unit.
- PACKAGING Code: AC8012100000023
- ACCESSORIES Code, according the order.